



HeFei GuoXuan High-Tech Power Energy Co Ltd

No.
Q/GX 021-2018

Title

IFP27175200A-105Ah Cone Ion Battery Product Specification

Page 1

13 Pages

IFP27175200A-105Ah Cone Ion Battery Product Specification

Provision	Revision	Approval
E2222 2018.3.13	李新峰 3.14	王成 3.14 ✓
Standardization 刘波 3.15	Countersign 王成 3.15	王成 3.15 ✓

禁止复印
受控副本
复印
王成 3.15
王成 3.15
王成 3.15

王成

Date of Publication

Date of Implement



Title

IFP27175200A-105Ah Cone Ion Battery Product Specification

Page 2

禁止
复制

13 Pages

2018-03-18

文控中心

Catalog

Foreword	3
Revision History	4
1. Scope	5
2. Normative References	5
3. Terms and Definitions	5
4. Basic Performance	6
5. Electrical Performance	6
6. Safety Performance	8
7. Test Methods	8
8. Test Regulations	11
9. Signs, Packaging, Transportation, Storage	12
Appendix A (Normative Appendix) Battery Dimensional Drawing	13



Title

IFP27175200A-105Ah Cone Ion Battery Product Specification

Page 3

13 Pages

禁止

2018-03-16

印

文控中心

Foreword

This standard is an enterprise standard that is implemented uniformly by the company. The format of this standard complies with the provisions of GB/T 1.1-2009 *Directives for standardization - Part 1: The structure and drafting of standards*.

This standard refers to GB/T 31484-2015 *Cycle life requirements and test methods for traction battery of electric vehicle*, GB/T 31485-2015 *Safety requirements and test methods for traction battery of electric vehicle*, GB/T 31486-2015. *Electrical performance requirements and test methods for traction battery of electric vehicle*, Q/GX 003-2015 *Technical Specifications of Cone-ion Power Battery for Electric Vehicles*, combined with the actual products and test conditions of our company, Q/GX 021-2018 *IFP27175200A-105Ah Cone-ion Battery Product Specification* standard, and amended and supplemented the test methods and judgment standards to guide the manufacture and acceptance of IFP27175200A-105Ah Cone-ion battery products.

This standard was proposed and drafted by the Battery Research Institute.

This standard is managed by the Department of Standards and Regulations.

The main drafters of this standard: Wang Shuangshuang and Wang Shixu.



HeFei GuoXuan High-Tech Power Energy Co Ltd

No.

Q/GX-021-2018

Title

IFP27175200A-105Ah Cone Ion Battery Product Specification

Page 4

2018 13 Pages

文控中心

Revision History

Version No.	Content Updated	Date of Revision	Revisor
Q/GX 021-2018			



1. Scope

This Product Specification specifies the normative performance, test methods, test methods, test regulations, and signs, packaging, transportation, storage requirements for IFP27175200A-105Ah Cone Ion Battery.

This Product Specification applies to the IFP27175200A-105Ah Cone Ion Battery manufactured by the company.

2. Normative References

The clauses in the following documents become the clauses of this standard through the quotation of this standard. However, all parties to agreements based on this standard are encouraged to study whether the latest versions of these documents can be used. For the cited documents without date, the latest version is applicable to this standard.

GB/T 2900.41 Electrotechnical terminology. Primary and secondary cells and batteries

GB/T 19596 Terminology of electric vehicles

GB/T 31484-2015 Cycle life requirements and test methods for traction battery of electric vehicle

GB/T 31485-2015 Safety requirements and test methods for traction battery of electric vehicle

GB/T 31486-2015 Electrical performance requirements and test methods for traction battery of electric vehicle

Q/GX 003-2015 Technical Specifications of Lithium-Ion Power Batteries for Electric Vehicles

3. Terms and definitions

3.1 Rated current: The abbreviations C, 1C indicate the current that the battery charges and discharges at a rate of 1 hour, and 3c indicates the current that the battery charges and discharges at a rate of 1/3 hour.

3.2 DC internal resistance: the battery is discharged at maximum pulse current for 10s at room temperature (25°C±2°C) and 50% SOC, calculate the voltage and current changes before and after discharge, and then divide the difference in voltage change by the current The difference between the changes is the DC internal resistance.

3.3 Maximum continuous charging current: The maximum current allowed for continuous charging of the battery at a specified temperature to ensure normal battery operation.

3.4 Maximum continuous discharge current: The maximum current allowed for continuous discharge of the battery at a specified temperature to ensure normal battery operation.

3.5 Constant current charging capacity ratio: the ratio of the battery's charging capacity at a certain rate to 3.65V cut-off at a certain rate at room temperature and 0% SOC to the charging capacity under standard charging methods.

3.6 Cold start power: under -20°C and 50% SOC, the battery's 2s pulse maximum discharge power

3.7 Product Model Meaning:

IF P 27 175 200 A - 105Ah

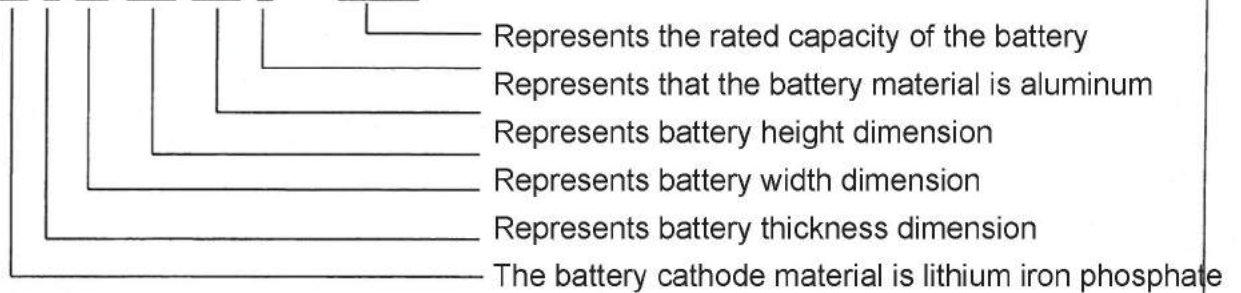

4 Basic Performance

Table 1 Basic Performance

Feature	Specification	Notes
4.1 Appearance		
4.2 Dimension	(27±0.5)mm*(175±0.3)mm* (200±0.3)mm	See Appendix A for details
4.3 Weight	(2060±50)g	
4.4 Nominal Voltage	3.2V	
4.5 AC Internal Resistance	(0.4~0.7)mΩ	
4.6 DC Internal Resistance	≤1.5mΩ	50%SOC
4.7 Rated Capacity	105Ah	
4.8 Working Voltage	2.0V~3.65V	
4.9 Cell Thickness	(27±0.5)mm	
4.10 Energy Density	163Wh/kg	

5 Electrical Performance

5.1 Charging Performance

Table 2 Charging Performance

Feature	Specification	Notes
5.1.1 Maximum Continuous Charging Current	0.1C	0℃~5℃ 0%SOC~80%SOC
	0.5C	5℃~15℃ 0%SOC~100%SOC
	1.0C	15℃~35℃ 0%SOC~100%SOC
	2.0C	15℃~35℃ 0%SOC~80%SOC
	0.5C	35℃~55℃ 0%SOC~100%SOC
5.1.2 Maximum Allowable Charging Voltage	3.9V	
5.1.3 Maximum Allowable Charging Temperature Range	0℃~55℃	

Table 2 Charging Performance (Continued)

Feature	Specification	Notes
5.1.4 Optimal Charging Temperature Range	10°C~35°C	
5.1.5 Constant Current Charging Capacity Ratio	>90%	2C

5.2 Discharge Performance

Table 3 Discharge Performance

Feature	Specification	Notes
5.2.1 Maximum Continuous Discharge Current	2C	Temperature rise <15°C (25°C)
5.2.2 Maximum Pulse Discharge Current	5C (10S)	Battery surface temperature ≤ 45°C, duration 10s, (at 25°C)
5.2.3 Minimum allowable discharge voltage	1.8V	Below 0°C discharge lower limit voltage
5.2.4 Maximum Allowable Discharge Temperature Range	-30°C~60°C	
5.2.5 Optimal Discharge Temperature Range	10°C~35°C	
5.2.6 Room Temperature Discharge Capacity	≥105Ah	
5.2.7 High Temperature Discharge Capacity	≥105Ah	55°C, 1C
5.2.8 Low Temperature Discharge Capacity/Energy Retention Rate	≥90% / ≥80%	0°C, 1C, Cut-off voltage 1.8V
	≥85% / ≥70%	-10°C, 1C, Cut-off voltage 1.8V
	≥80% / ≥60%	-20°C, 1C, Cut-off voltage 1.8V
	≥70% / ≥50%	-30°C, 1C, Cut-off voltage 1.8V
5.2.9 Rated Discharge Capacity Retention Rate	≥95%	
5.2.10 Charge and Discharge Energy Efficiency	≥90%	

5.3 Power Performance

Table 4 Power Performance

Feature	Specification	Notes
5.3.1 Mass Power Density	≥1300W/kg	50%SOC, 25°C
5.3.2 Volume Power Density	≥2500 W/L	50%SOC, 25°C
5.3.3 Maximum Discharge Power	2500W	50%SOC, 25°C, see 7.10
5.3.4 Maximum Feedback Power	1400W	50%SOC, 25°C, see 7.10
5.3.5 Cold Start Power	60W	50%SOC, -20°C

5.4 Battery Life

Table 5 Battery Life

Feature	Specification	Notes
5.4.1 Standard cycle life	≥ 3000 times	25°C, 1C, see 7.12
5.4.1 High temperature cycle life	≥ 1500 times	45°C, 1C, see 7.12
	≥ 800 times	55°C, 1C, see 7.12
5.4.1 Calendar life	≥ 10 years	see Q/GX 003-2015, 5.1.18

5.5 Battery Life

Table 6 Storage Performance

Feature	Specification	Notes
5.5.1 Optimal storage temperature range	10°C ~ 30°C	
5.5.2 Self-discharge rate	$\leq 4\%$	25°C, 28
5.5.3 Room temperature charge retention rate	$\geq 96\%$	25°C, 28 days, see 7.8
5.5.4 Room temperature charge recovery rate	$\geq 97\%$	
5.5.5 High temperature charge retention rate	$\geq 95\%$	55°C, 7 days, see 7.8
5.5.6 High temperature charge recovery rate	$\geq 96\%$	
5.5.7 Recovery rate of storage capacity	$> 95\%$	45°C, 50%SOC, 28 days,

6 Safety Performance

Table 7 Safety Performance

Feature	Specification	Notes
6.1 Overdischarge	No explosion, no fire, no leakage	GBT 31485-2015
6.2 Overcharge	No explosion, no fire	GBT 31485-2015
6.3 Short circuit	No explosion, no fire	GBT 31485-2015
6.4 Drops	No explosion, no fire, no leakage	GBT 31485-2015
6.5 Heating	No explosion, no fire	GBT 31485-2015
6.6 Extrusion	No explosion, no fire	GBT 31485-2015
6.7 Seawater immersion	No explosion, no fire	GBT 31485-2015
6.8 Temperature cycle	No explosion, no fire, no leakage	GBT 31485-2015
6.9 Low pressure	No explosion, no fire, no leakage	GBT 31485-2015

7 Test Methods

7.1 Test Environment



Unless otherwise noted, the battery test environmental conditions are: temperature $25^{\circ}\text{C}\pm 2^{\circ}\text{C}$, relative humidity is

Atmospheric pressure 86kPa~106kPa; battery charging adopts 7.2 mode; battery discharging adopts 7.3 mode; the room temperature mentioned in this standard refers to $25^{\circ}\text{C}\pm 2^{\circ}\text{C}$.

7.2 Standard charging

At room temperature ($25^{\circ}\text{C}\pm 2^{\circ}\text{C}$), the single battery discharges at a current of 1C to a voltage of 2.0V, stands still for 1h, and then charges at a current of 1C to a voltage of 3.65V, then turns to constant voltage charging to the charging current Stop charging when it drops to 0.05C, let it stand for 1ho after charging

7.3 Standard discharge

First fully charged according to 7.2, at room temperature, the single battery discharges at a current of 1C to a voltage of 2.0V cutoff.

7.4 DC internal resistance

Charge according to 7.2 method, discharge at 1C current for 30min at room temperature, and discharge at 5c current for 10s, calculate the voltage and current changes before and after discharge, and then divide the difference in voltage change by the difference in current change.

7.5 Low temperature discharge capacity

Charge according to the method of 7.2; store for 20h at the temperature specified in 5.2.8; discharge at a current of 1C at the corresponding temperature and discharge to 1.8V0. Test the discharge capacity at different temperatures according to this method.

7.6 High temperature discharge capacity

Charge according to 7.2 method; store at $55^{\circ}\text{C}\pm 2^{\circ}\text{C}$ for 5h; discharge at $55^{\circ}\text{C}\pm 2^{\circ}\text{C}$ with 1C current and discharge to 2.0V to obtain high temperature discharge capacity.

7.7 Room temperature rate charge and discharge capacity

At room temperature, discharge according to the 7.3 method, and perform constant current charging to 3.65V at the specified rate, respectively, to obtain different rates

0's charging capacity; at room temperature, charge in 7.2 method, and discharge to 2.0V at the specified rate, respectively, to obtain different rates

Discharge capacity.

7.8 Charge retention rate, self-discharge rate and capacity recovery rate

Charge according to the method of 7.2. After storing at room temperature for 28 days or at $55^{\circ}\text{C}\pm 2^{\circ}\text{C}$ for 7 days, discharge to 2.0V at 1C current to obtain the discharge capacity. The ratio of the initial capacity is the charge retention rate;

Then press 7.2 method to charge and 7.3 method to discharge to get the recovery capacity, the ratio of the initial capacity is the capacity recovery rate

The difference between the room temperature capacity recovery rate and the room temperature charge retention rate is the battery self-discharge rate.



7.9 Recovery rate of storage capacity

Charge according to 7.2 method, discharge at room temperature with 1C current for 30min, store at $45^{\circ}\text{C}\pm 2^{\circ}\text{C}$ for 28 days, charge according to 7.2 method, discharge at room temperature with 1C current to 2.0V, get discharge capacity, The ratio of the initial capacity is the storage capacity recovery rate.

7.10 Maximum discharge power and maximum feedback power

According to the methods of 7.3, 7.5 and 7.6, the discharge capacity at different temperatures is obtained, and this is used as the SOC calculation standard at different temperatures; (5h; $\leq 0^{\circ}\text{C}$, 20h), adjust the SOC to 90% with 1C current discharge, after standing for 1h, discharge with the current maximum current pulse of 5c for 10s, set aside for 40s, and then charge with the current temperature to allow pulse 3.75C current 10s; adjust the SOC to 80%, 70%, ...10% in turn with 1C current, test the pulse charge and discharge capacity under different SOC, record the process data, according to the DC in the HPPC test method

The calculation formula of internal resistance and pulse power calculates the maximum discharge power and maximum feedback power at different temperatures and SOC.

7.11 Cold start test

Charge according to 7.2 method, discharge to 50% SOC at 1C current at room temperature, place the battery at -20°C for 20h, then discharge at 5kW/BSF for 2s at -20°C , and then stand for 10s, Repeat 3 times (see Q/GX 003-2015, 5.1.15 for BSF).

7.12 Standard cycle life and high temperature cycle life

7.12.1 Standard cycle life

The battery is charged at a constant current of 1C to 3.65V to constant voltage at room temperature, until the current drops to 0.05C, cut off for 10 minutes, and then discharged at a current of 1C to 2.0V. The discharge capacity should not be low when repeated 500 times. The discharge capacity should not be less than 80% of the rated capacity at 93% of the rated capacity, or when the number of cycles reaches 3000.

7.12.2 45°C cycle life

The battery is charged at a constant current of 1C to 3.65V to a constant voltage under a 45°C environment until the current drops to 0.05C, and it is allowed to stand for 10 minutes. Then discharge to 2.0V with 1C current, and the discharge capacity should not be less than 80% of the rated capacity when repeated 1500 times.

7.12.3 55°C cycle life

The battery is charged at a constant current of 1C to 3.65V to a constant voltage at 55°C , until the current drops to 0.05C, cut off for 10 minutes, and then discharged to 2.0V at a current of 1C. The discharge capacity should not be exceeded after repeating 800 times Less than 80% of rated capacity.



8 Test regulations

8.1 Test items according to the provisions of Table 8

Table 8 Test items

Test type	Test items	Test quantity
Test-free items	4.4 Nominal voltage 4.7 Rated capacity 4.8 Working voltage 5.1.2 Maximum allowable charging voltage 5.1.3 Maximum allowable charging temperature range 5.1.4 The best charging temperature range 5.2.3 The minimum allowable discharge voltage 5.2.4 Maximum allowable discharge temperature range 5.2.5 The best discharge temperature range 5.5.1 Optimal storage temperature range	/
Factory test	4.1 Appearance 4.5 AC internal resistance 5.2.6 Room temperature discharge capacity 5.5.2 Self-discharge rate	100%
	4.2 Size 4.3 Weight	160 pcs/batch
Type test	Other indexes except inspection-free items and factory inspection items: 4.6 DC internal resistance 5.1.1 Maximum continuous charging current 5.1.6 Constant current charging capacity ratio 5.2.1 Maximum continuous discharge current 5.2.2 Maximum pulse discharge current 5.2.7 High temperature discharge capacity 5.2.8 Low temperature discharge capacity/energy retention rate 5.2.9 Rated discharge capacity retention rate 5.3.1 Mass power density 5.3.2 Volumetric power density 5.3.3 Maximum discharge power 5.3.4 Maximum feedback power 5.3.5 Cold start power 5.4.2 High temperature cycle life 5.4.3 Calendar life 5.5.3 Room temperature charge retention rate 5.5.4 Room temperature capacity recovery rate 5.5.5 High temperature charge retention rate 5.5.6 High temperature capacity recovery rate 5.5.7 Recovery rate of storage capacity 6.1 Overdischarge 6.2 Overcharge 6.3 Short circuit 6.4 Drop 6.5 Heating 6.6 Extrusion 6.7 Seawater immersion 6.8 Temperature cycle 6.9 Low air pressure	2 pcs/type

8.2 Factory inspection and judgment rules

Table 9 Judgment and treatment of battery level

Battery Level	Index Requirement
A	Capacity ≥ 105 Ah, < 115.5 Ah
B	Capacity ≥ 94.5 Ah, < 105 Ah
C	Capacity ≥ 84 Ah, < 94.5 Ah
D	The battery whose electrical performance does not meet the requirements of A, B, and C files; the battery thickness ≥ 127.5 mm



8.3 Type inspection

8.3.1 The product shall undergo type inspection in one of the following situations:

- a) New products are put into production and old products are converted;
- b) Transfer to factory;
- c) resume production after more than one year of suspension;
- d) Structure; major changes in process or materials.

8.3.2 Judgment rules

In the type inspection, if there is a failure, it shall be judged as failure.

9 Signs, packaging, transportation, storage

9.1 Logo

Each product should have a clear barcode.

9.2 Packaging

All products should have external packaging to ensure that the products are not mechanically damaged during transportation, loading, unloading and stacking.

9.3 Transportation

During transportation, violent loading and unloading should be strictly prohibited to prevent violent vibration, impact or squeeze, and to prevent sunlight and rain.

9.4 Storage

The product without opening the package should be stored in a clean, dry and ventilated warehouse with an ambient temperature of $-10^{\circ}\text{C}\sim 30^{\circ}\text{C}$ and a relative humidity of $\leq 75\%$. The warehouse should not contain corrosive gases; the product should be kept away from fire and heat source; the charging cycle should be carried out regularly not exceeding 2 months.

Appendix A

(Normative appendix)

Battery size diagram

A.1 The battery size is shown in Figure A.1

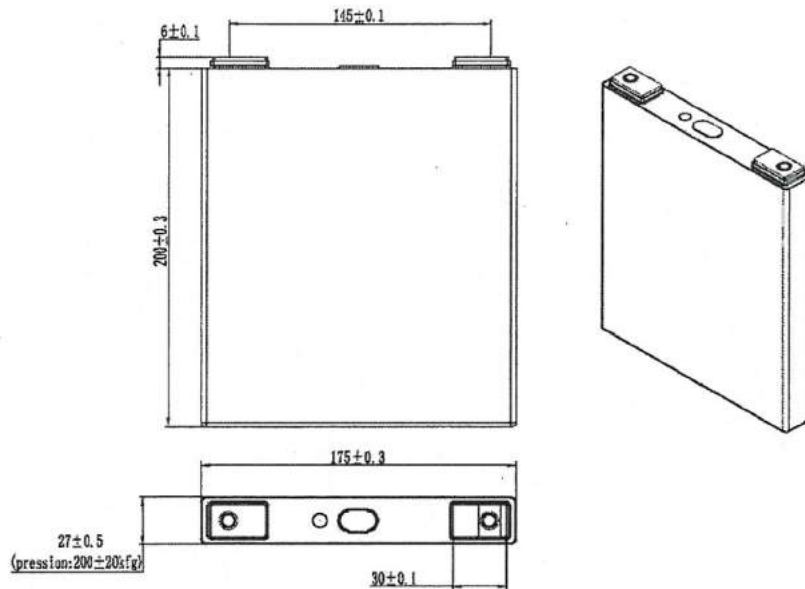

Figure A.1 Battery size diagram

